

PLATEN, 3.00" UPPER

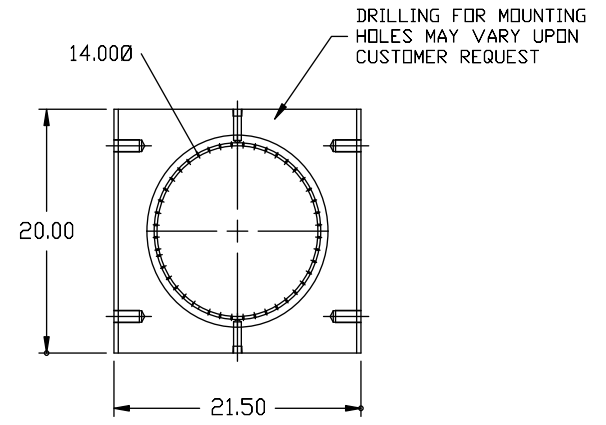

PLATEN, 3.00" LOWER

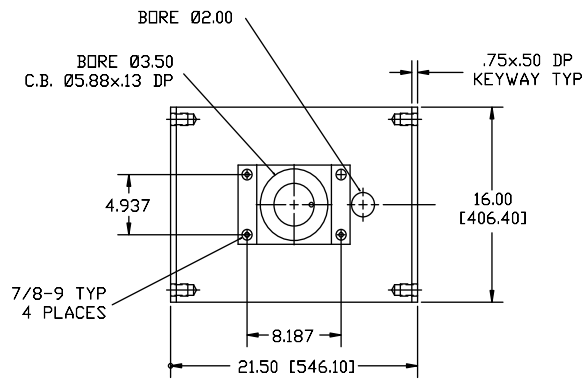

PLATEN, 2.50" EJECTOR

KEY: INCHES[M.M.]

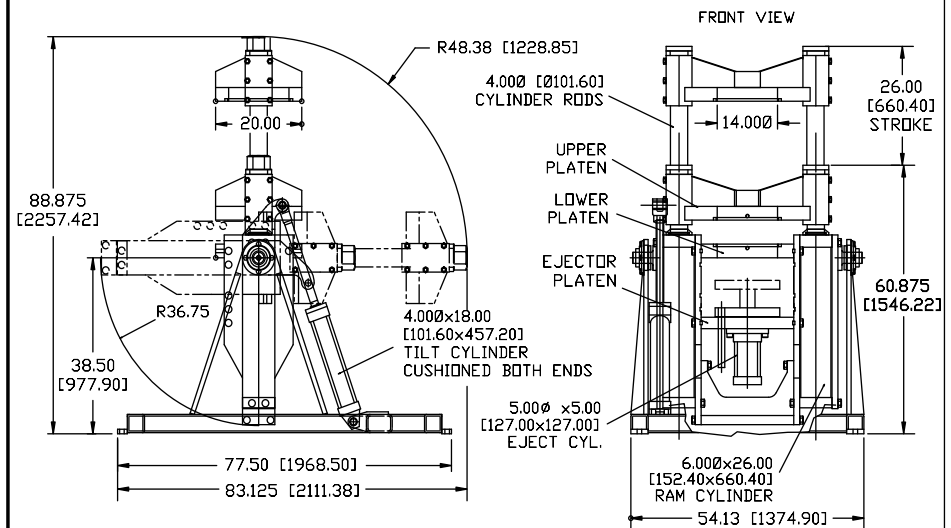

PERMANENT MOLD MACHINES